

63,4kWh, 351V



SUPPORTED VEHICLES



SYSTEM FEATURES

- + Bus, truck, light commercial mini bus, construction machines, agriculture, marine and ground support equipment application
- + Freely scalable and robust structure
- + Common PJB (Pack Junction Box) for all products
- + Efficient liquid cooling system
- + CANBus 2.0A-B communication protocol
- + Integrated BMS (Battery Management System)
- + Integrated precharge circuit and isolation measurement
- + IATF 16949:2016, ECER100.2, ECER10.6 and UN38.3 certifications
- + Lloyd certification (2024-Q3)
- + Compatible design according to ISO 26262 up to ASIL C - possible



BATTERY PACK LAYOUT

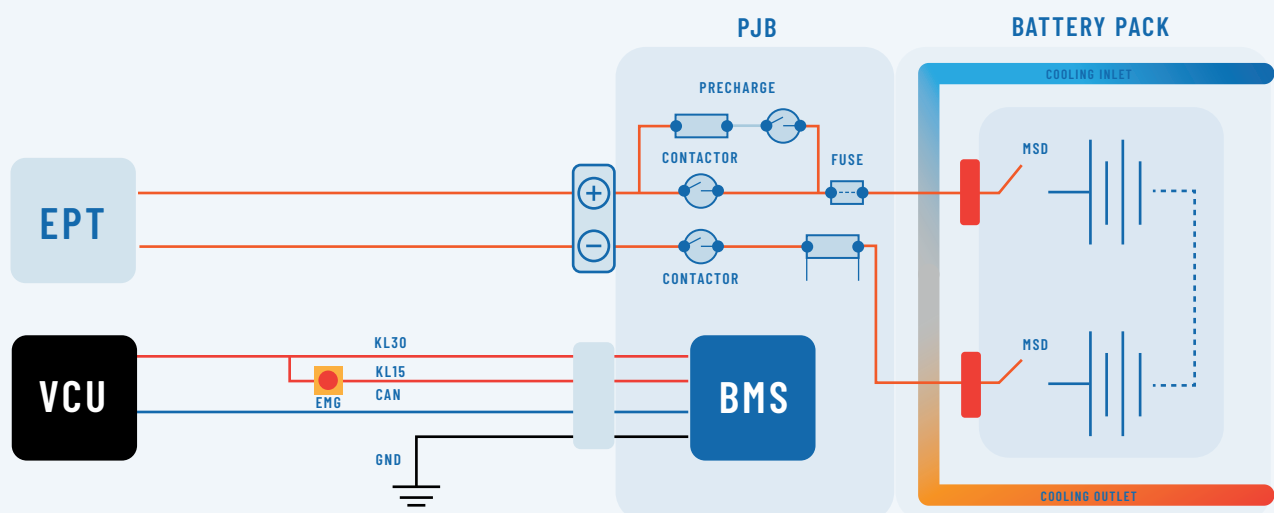

ELECTRICAL SPECIFICATIONS

	VALUE	UNIT
Cell Chemistry	NMC	
Installed Energy @1/3C	63,4	kWh
Energy Density @1/3C	up to 174	Wh/kg
Capacity @1/3C	177	Ah
Nominal Voltage	351	V
OCV Range @ 5-95% SoC	334 - 406	V
Min-Max Voltage Range	269 - 418	V
Cont. Charge Current @ 25°C, SoC dependent, step charge	209	A
Peak Charge Current @ 25°C, SoC dependent	348	A
Cont. Discharge Current @ 25°C, SoC dependent	174	A
Peak Discharge Current @ 25°C, SoC dependent	500	A
Cycle Life (based on user power profile, DoD and temp.)	> 2000	cycle
Communication Protocol	CANBus 2.0A-B	
Supply Voltage for Control Equipment	12/24	V

MECHANICAL SPECIFICATIONS

	VALUE	UNIT
Cooling Type	Liquid Cooling	
Flow Rate	10-15	l/min
Pressure Drop @10l/min and 25°C	< 300	mbar
Coolant Operating Pressure	< 2	bar
Operating Temperature @discharge	-30 ~ 55	°C
Operating Temperature @charge	-20 ~ 55	°C
Recommended Operating Temperature	15 ~ 35	°C
Storage Temperature	-30 ~ 55	°C
IP Rating (when the plug connectors are mated)	IP67	
Weight (based on the type of housing)	365	kg
Dimensions-1F24 (L x W x H)	1660x1000x145	mm

MULTIPLE BATTERY SYSTEM

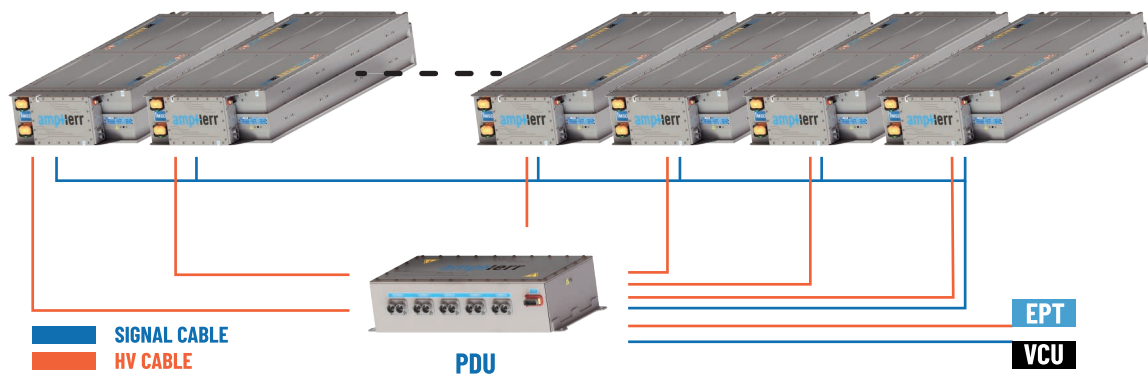

NMC-400-063F / 05.2024

AMPHERR AG

Sperberweg 18
41468 Neuss
sales@ampherr.com

ampherr

Redefinition of Current!